



CENTRALIZERS



Features

- Reduces wear on tubing in deviated wells
- 4340 Heat-Treated Stress-Relieved Mandrel with Rolled Threads
- Field Replaceable Nylon Rotor
- Rotor Interchangeable Between 1" and 1-1/8" couplings

Coupling Dimensional Info

Pin Size (in.)	Tubing Size (in.)	Part Number	Rotor Diameter D (in.)	Flow Area A (sq. in.)		Notes
				Min (1)	Max (2)	
3/4	2-3/8"	3/4 x 2-3/8	1.85	0.39	0.92	(3)
7/8	2-7/8"	7/8 x 2-7/8	2.27	0.81	1.25	(4)
	3-1/2"	7/8 x 3-1/2	2.79	1.42	2.11	(5)
1	3-1/2"	1 x 3-1/2	2.79	1.42	2.11	(5)
	4-1/2"	1 x 4-1/2	3.21	2.94	6.99	
1-1/8	3-1/2"	1-1/8 x 3-1/2	2.79	1.42	2.11	(6)
	4-1/2"	1-1/8 x 4-1/2	3.21	2.94	6.99	(6)

Notes:

- 1.) Based on heaviest allowable tubing as per API 5CT, unless specified otherwise
- 2.) Based on lightest tubing as per API 5CT
- 3.) 1.867 Min. Tubing ID

- 4.) 2.323 Min. Tubing ID
- 5.) 2.922 Min. Tubing ID
- 6.) Ships with 1-1/8 Couplings

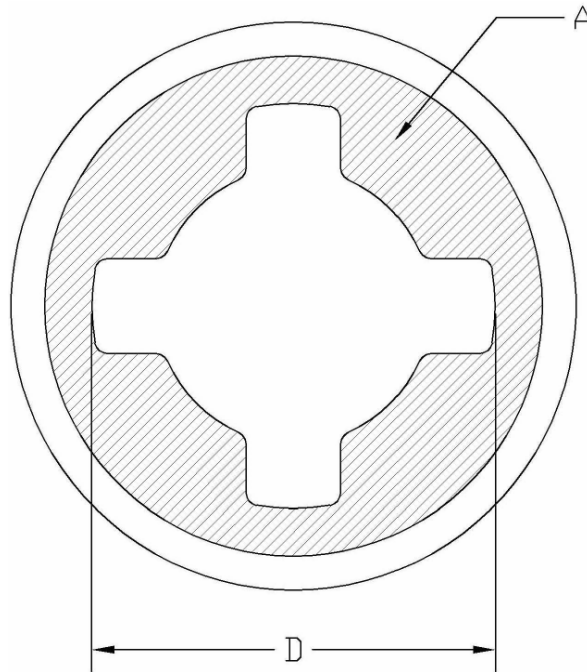

Material Specification

Mandrel: 4340 HTSR
Rotor: Nylon 6, CL200-001 (standard) Other Rotor Materials Available
Max. Operating Temperature: 104 ° C (Nylon 6)

Ordering Information

1. Specify Pin Size
2. Specify Tubing Size.